

11. THERMAL BRIDGING

IN THIS CHAPTER

- 11.1 Overview of thermal bridging
- 11.2 Modelling thermal bridging
- 11.3 Default steel framing specifications
- 11.4 Modelling thermal breaks and airspaces adjacent to framing
- 11.5 Additional constructions modelling guidance

SUPERSEDED

11. THERMAL BRIDGING

This chapter explains thermal bridging and includes details on how to model thermal bridges in walls, floors, ceilings and roofs.

It also explains thermal breaks and outlines the requirements for how to model these, including the default values to use when thermal break specifications are not included in design documentation.

Summary of key requirements

This handbook is intended to be a helpful resource for all assessors. When conducting assessments, assessors must still follow the requirements of the current NatHERS Technical Note and the relevant state or territory requirements.

11a Thermal bridging only applies to repeating steel frame elements where insulation is interrupted. Thermal bridging is applied in walls, ceiling and floors as outlined in Table 6 of the NatHERS Technical Note.

11b Assessors must model thermal bridging that occurs in the design documentation in accordance with the software's instructions. If the software has the functionality to select specific metal framing specifications, these may be used to apply thermal bridging to the relevant elements. When steel framing details are not supplied and if the software has the functionality, assessors must model the default steel framing specifications outlined in Table 7 of the NatHERS Technical Note.

11c Thermal break materials must have a minimum R-value of R0.2 as specified by the 2022 National Construction Code (NCC).

11d Assessors must model thermal breaks according to the NCC 2022 requirements and as specified in the design documentation in accordance with the software's instructions. When thermal breaks are required as per the NCC 2022 provisions but are not specified in the design documentation, assessors must model the default value R0.2 and refer to Table 8 of the NatHERS Technical Note.

11e Assessors must enter an additional R0.16/air gap to thermally bridged construction types detailed in this chapter whilst referring to individual software guidance notes for specific modelling instructions.

11.1 Overview of thermal bridging

11.1.1 What is a thermal bridge?

A thermal bridge, also known as a heat bridge or a cold bridge, is a part of the building envelope with lower thermal resistance than surrounding areas. This enables heat to pass more easily through the building envelope. It typically occurs where there is an interruption to insulation caused by a structural element that has a higher thermal conductivity than the surrounding material.

Any solid material can act as a thermal bridge. It can be a single structural element – a steel beam for example. It can also be a combination of elements that are in direct contact with each other – for example, external cladding fixed directly to a structural frame that itself is directly fixed to the internal lining or is open to the internal environment. See Figure 11-1 below.

The bridge's thermal conductivity will determine how much heat or cold it can transfer. For example, steel has a higher thermal conductivity than common structural timber so it creates a stronger pathway of least resistance for heat or cold to transfer.

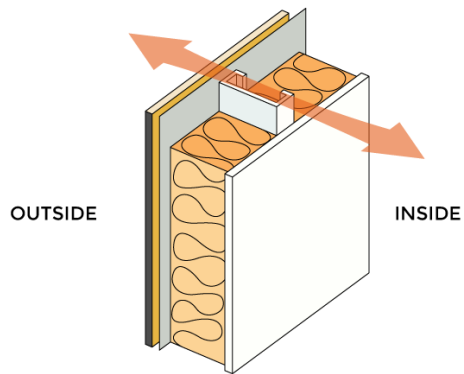

Figure 11-1: Direct-fixed steel framed wall showing the thermal path of least resistance through the steel frame, with no thermal break (non-compliant construction).

11.1.2 Impacts of thermal bridging

Thermal bridges can reduce the energy efficiency of a building by transferring heat or cold into or out of a building. This can increase the energy needed to heat or cool the building.

Thermal bridges can also cause condensation when warm moist inside air meets the cold surface of the bridge. If the temperature of the thermal bridge material falls below the dewpoint, moisture can condense on the inner surface. This can lead to mould growth and, if excessive, may also damage structural elements within a building over time.

In the case of a non-compliant direct-fix clad external wall (seen in Figure 11-2 below), the temperature of the internal lining in contact with the steel frame will be closer to the outside temperature. On a cold day, the temperature of this section of the internal lining may dip below the dewpoint of the indoor air causing condensation to form. This may lead to localised problems such as patterned staining if not mitigated against.

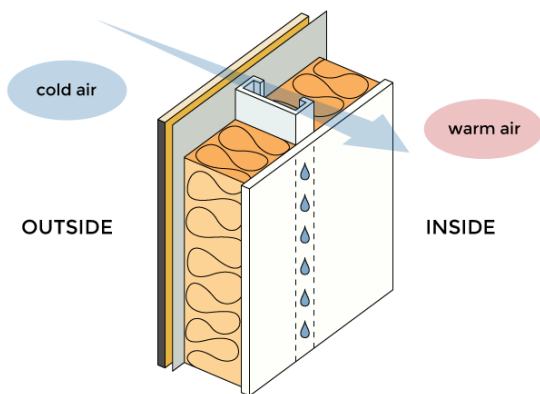

Figure 11-2: Condensation may form on the internal lining if thermal bridging is not mitigated (non-compliant construction).

11.1.3 What is a thermal break?

A thermal break or a thermal barrier is the opposite of a thermal bridge. It includes any material that interrupts the conduction of heat or cold between building elements. Thermal breaks counteract the effects of thermal bridging, reducing heat loss and/or gain and subsequently improving the overall energy efficiency of a building. See Figure 11-3 and Figure 11-4 below.

As defined by the NCC 2022, thermal breaks are materials with an R-value greater than or equal to R0.2 that are installed between and separate the cladding from the frame. This includes, but is not limited to:

- materials such as timber battens greater than or equal to 20 mm thick
- expanded polystyrene strips greater than or equal to 12 mm thick
- continuous thermal breaks such as polystyrene insulation sheeting deemed to achieve an R-value greater than or equal to R0.2.

The NCC provisions require thermal breaks for walls to be installed at all points of contact between the external cladding and the metal frame. This is in scenarios when the wall does not have a wall lining or has a wall lining that is fixed directly to the metal frame and is clad with weatherboards, fibre-cement or the like, or metal sheeting fixed to the metal frame. See Figure 11-3 below.

The NCC provisions require thermal breaks for roofs to be installed between the metal sheet roofing and its supporting metal purlins, metal rafters or metal battens. This is in circumstances where the metal sheet roofing is directly fixed to metal purlins, metal rafters or metal battens and does not have a ceiling lining, or has a ceiling lining fixed directly to those metal purlins, metal rafters or metal battens. See Figure 11-4 below.

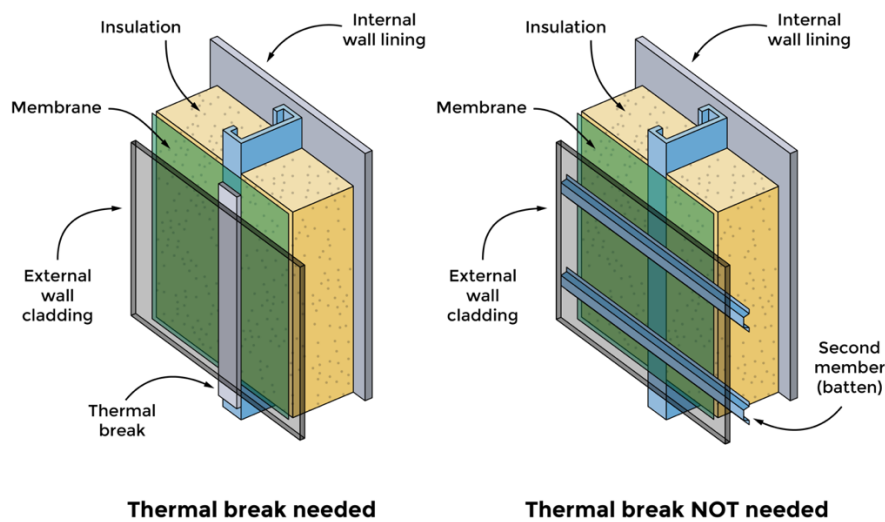

Figure 11-3: A minimum R0.2 thermal break is required to be installed at all points of contact between the external cladding and the metal frame when lightweight cladding is attached to the same steel member as the internal lining in an insulated steel framed wall. Image source: The NCC Housing energy efficiency Handbook provided by the Australian Building Codes Board under the CC BY 4.0 licence, March 2023.

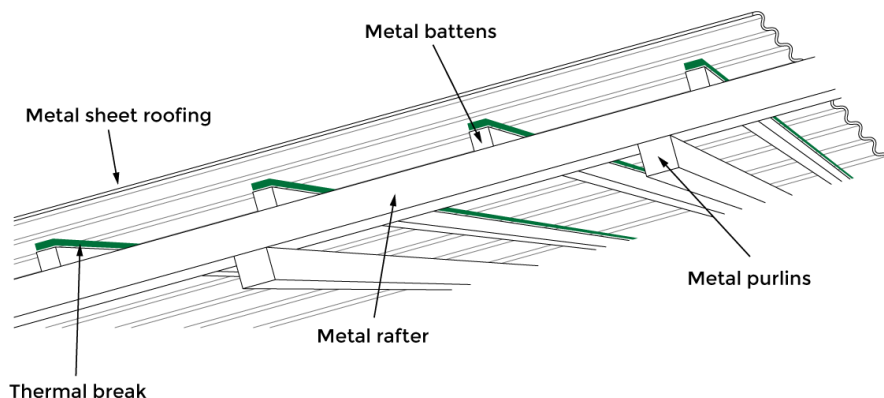

Figure 11-4: A minimum R0.2 thermal break in a roof construction (insulation not shown). Image source: The NCC Housing energy efficiency Handbook provided by the Australian Building Codes Board under the CC BY 4.0 licence, March 2023.

11.1.4 Thermal bridging in NatHERS

NatHERS has been modified to include a thermal bridging function to align with the NCC 2022 requirements. The current thermal bridging implementation methodology can be found in Thermal Bridging Implementation in AccuRate Report (2023): https://www.nathers.gov.au/sites/default/files/2023-05/ThermalBridgingImplementation_20230403_V5_FINAL.pdf. This report also includes a comparison of energy rating results between the previous method and the current method. Thermal bridging impacts are based on the calculation method outlined in standard NZS 4214:2006 *Methods of determining the total thermal resistance of parts of buildings*.

In 2020 in preparation for the thermal bridging updates to the NCC, a Thermal Bridging Report (2020) was published by CSIRO: https://nathers.govcms.gov.au/sites/default/files/2021-08/nathers_2022_thermal_bridging_report.pdf. This report includes a set of thermal bridging default parameters and draft modelling guidance, as well as the impact of applying defaults on residential building energy ratings.

As guided by the NCC 2022 requirements, modelling of thermal bridging in NatHERS is only required for repeating steel framed elements. It is not applied to timber framed constructions. The performance of steel framed buildings must now achieve a similar performance to timber framed buildings; i.e. thermal bridging calculations will be based on a comparison to timber framing as a benchmark rather than the actual performance of steel frames. Assessors will have the option of adding thermal breaks and/or improving other elements of the home's design to offset any negative impacts associated with thermal bridging. The diagrammatic images below in Figure 11-5 show examples of repeating steel frame elements for the roof, wall and floor.

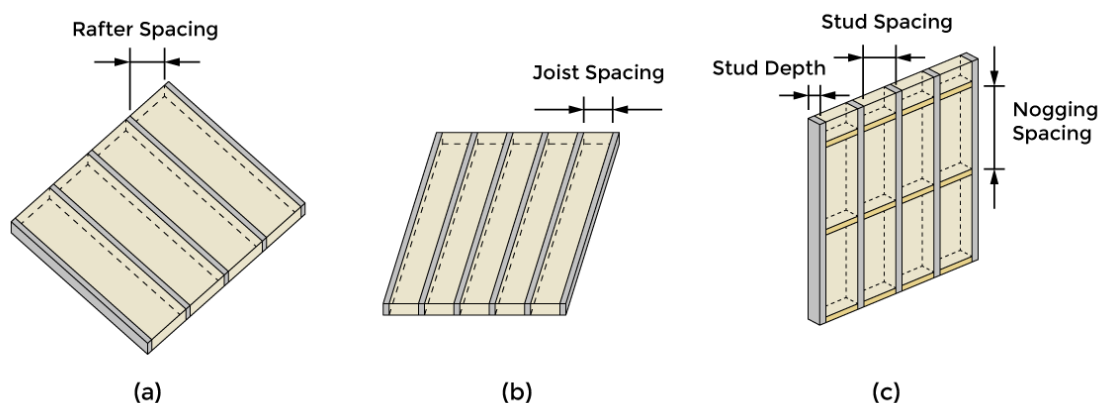

Figure 11-5: Diagrammatic illustrations of thermal bridging in insulated, repeating steel frame elements for (a) roof without a roof cavity, (b) floor or ceiling with a roof cavity and (c) wall.

11.2 Modelling thermal bridging

Thermal bridging modelling in NatHERS applies to repeating steel frame elements only where insulation is interrupted by the steel framing. As a minimum, assessors must apply thermal bridging to the steel framed building elements outlined in Table 11-1 (Table 6 in the NatHERS Technical Note) and illustrated in Figures 11-6 and 11-7. Assessors may also model the effects of thermal bridging for additional features if they exist, to improve the thermal modelling accuracy and if the software allows using appropriate thermal modelling techniques.

Table 11-1

Building element	When to apply thermal bridging
External walls (Class 1)	Apply to all Ignore external walls of attached unconditioned garage
Apartment walls (Classes 2 & 4)	Apply if adjacent to non-neighbour spaces such as stair wells, corridors, car parks and other shared public spaces Ignore if adjacent to neighbour
Internal walls	Apply if adjacent to: <ul style="list-style-type: none"> unconditioned garages roof spaces subfloor zones Ignore all other internal walls
Ceilings	Apply to ceilings: <ul style="list-style-type: none"> below a roof space directly attached to a roof (e.g. flat, skillion, cathedral) non-neighbour public areas Ignore if adjacent to another zone (excluding roof space)
Floors	Apply to suspended floors above: <ul style="list-style-type: none"> outside air (including sub-floors) unconditioned garage non-neighbour public area Ignore if: <ul style="list-style-type: none"> in-between floors of multi-level Class 1 building adjacent to neighbour zone

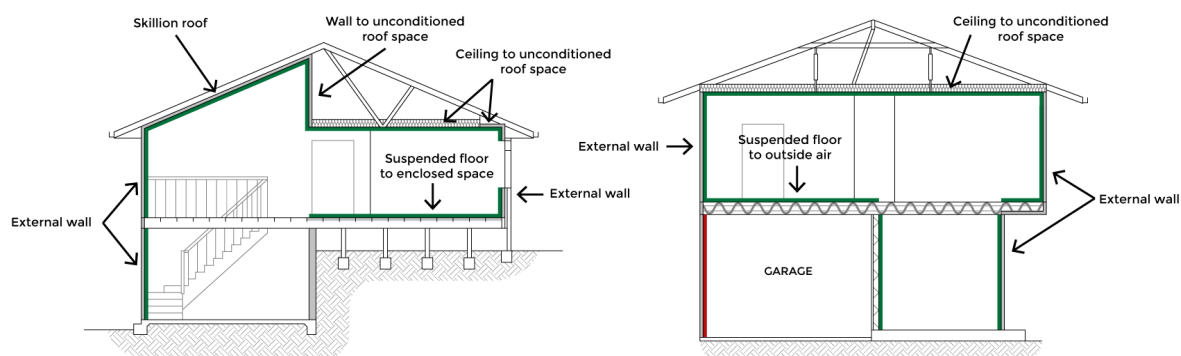

Figure 11-6: Class 1 examples of steel frame building elements that require thermal bridging to be modelled outlined in green.

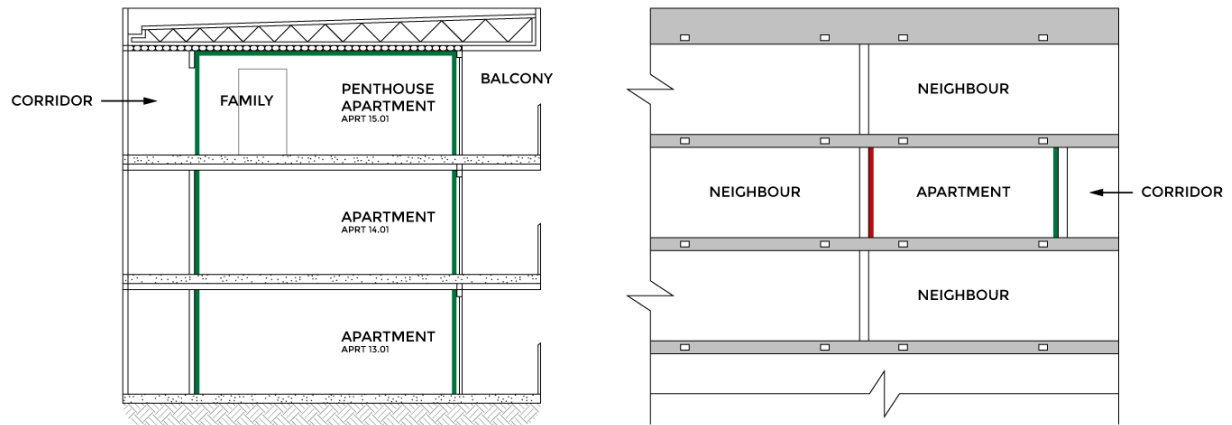

Figure 11-7: Class 2 & 4 examples of building elements that require thermal bridging to be modelled outlined in green.

11.3 Default steel framing specifications

Assessors must model thermal bridging that occurs in the design documentation in accordance with the software’s instructions. If the software has the functionality to select specific metal framing specifications, these may be used to apply thermal bridging to the relevant elements. When steel framing details are not supplied and if the software has the functionality, assessors must model the default steel framing specifications outlined in Table 11-2 (Table 7 of the NatHERS Technical Note).

Table 11-2

Building feature	Frame element	Steel frame dimensions
Ceiling/roof without roof cavity	Rafter	200 x 75 mm
	Rafter spacing	900 mm
	Flange width	75 mm
	Base metal thickness	1.5 mm
Ceiling with roof cavity elements – raftered roofs with concealed rafters or horizontal ceilings Apply to edge batts as well as centre/non-edge batts	Joist	90 x 40 mm
	Joist spacing	900 mm
	Flange width	40 mm
	Base metal thickness	0.75 mm
Wall	Stud	90 x 40 mm
	Stud spacing	600 mm
	Flange width	40 mm
	Base metal thickness	0.75 mm
	Nogging dimensions	90 x 40 mm
Floor	Nogging spacing	1200 mm
	Joist	100 x 50 mm
	Joist spacing	450 mm
	Flange width	50 mm
	Base metal thickness	1.5 mm

Flange width and base metal thickness measurements are illustrated in Figure 11-8 below.

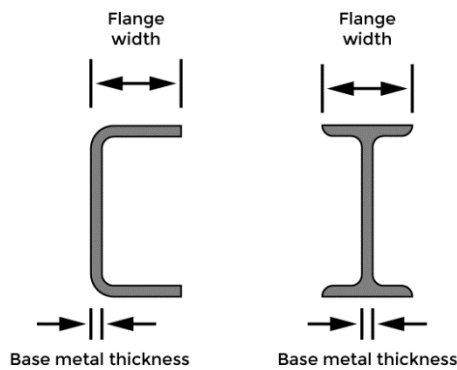

Figure 11-8: Flange width and base metal thickness measurements.

11.4 Modelling thermal breaks and airspaces adjacent to framing

Thermal breaks can only be modelled after thermal bridging has been applied. As per the NCC 2022 requirements, thermal breaks must have an R-value greater than or equal to R0.2.

Assessors must model any thermal breaks specified in the design documentation in accordance with the software's instructions. When thermal breaks are not specified in the design documentation, assessors must model the default values as specified in Table 11-3 (Table 8 from the NatHERS Technical Note).

Table 11-3

Element	Construction	Thermal break minimum R0.2 ^{1 2}	Air gap R0.16 ³
External walls	Cavity ⁴	No	Yes
	Lightweight clad ⁵ (direct fixed to the same insulated steel member as the wall lining, or does not have a wall lining)	Yes	No
	Lightweight clad (battened out by secondary members fixed to the frame)	No	Yes
Internal walls to unconditioned space/s	Cavity	No	Yes
	Lightweight cladding (direct fixed to the same insulated steel member as the wall lining, or does not have a wall lining)	Yes	No
	Lightweight cladding (battened out by secondary members fixed to the frame)	No	Yes
	Above attic space	No	No

¹ Thermal breaks are materials with an R-value greater than or equal to R0.2 installed at all points of contact between the external cladding and the frame. This includes, but is not limited to, materials such as timber battens greater than or equal to 20 mm thick, expanded polystyrene strips greater than or equal to 12 mm thick or continuous thermal breaks such as polystyrene insulation sheeting greater than or equal to R0.2.

² NCC 2022 compliant construction includes a minimum thermal break R0.2

³ If the software has the functionality

⁴ E.g. masonry or brick veneer

⁵ Lightweight cladding includes weatherboard, fibre-cement or metal clad.

Element	Construction	Thermal break minimum R0.2 ^{1 2}	Air gap R0.16 ³
Metal sheet roofs	Skillion or cathedral metal roof with metal sheet roofing and ceiling lining directly fixed to the main frame	Yes	No
	Skillion or cathedral metal roof battened-out by secondary metal members, with or without a ceiling lining	Yes	Yes 1 x R0.16 if roof battens are present 1 x R0.16 if ceiling battens are present
Ceilings	Ceilings below attic spaces	No	Yes
Floors	Suspended floor above and exposed to an enclosed subfloor space e.g. no bottom lining	No	Yes
	Suspended floor above unconditioned garage, outdoor air or non-neighbour	No	No

To align NatHERS modelling with established thermal bridging calculation methods, assessors must enter an additional R0.16 air gap to the following, referring to individual software guidance notes for specific modelling instructions. See Table 11-3 above (Table 8 from the NatHERS Technical Note):

For walls:

Apply an R0.16/air gap option to any thermally bridged external cavity walls⁶ or thermally bridged internal cavity walls adjacent to an unconditioned garage or roof spaces. See Figure 11-9 below.

Apply an R0.16/air gap option to any lightweight clad⁷ wall construction where the internal or external cladding is not directly fixed to the main steel frame, for example fixed via secondary metal battens perpendicular to the frame. See Figure 11-9 below.

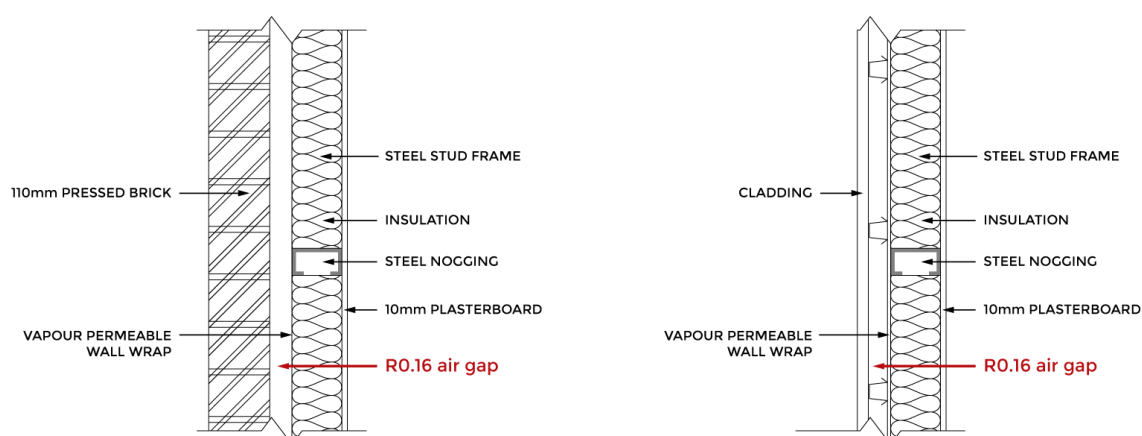

Figure 11-9: Modelling air gaps in steel framed brick veneer and battened out lightweight clad walls.

For roofs:

⁶ For example masonry or brick veneer

⁷ Lightweight cladding includes weatherboard, fibre-cement or metal clad

Skillion or cathedral roof – if available in the software apply an R0.16 air gap option if metal roof battens are shown in the design documentation. If available in the software apply an R0.16 air gap if metal ceiling battens are shown in the design documentation. See Figure 11-10 below.

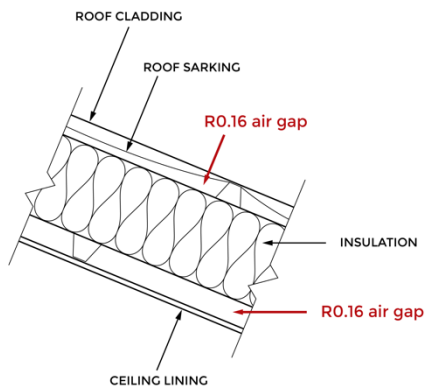

Figure 11-10

Ceiling with unconditioned roof space above – if available in the software apply an R0.16 air gap if secondary metal ceiling battens are shown in the design documentation. Ceiling battens are typically used for ceiling frame spacing greater than 600 mm (i.e. 900/1200/1500 centres). See Figure 11-11 below.

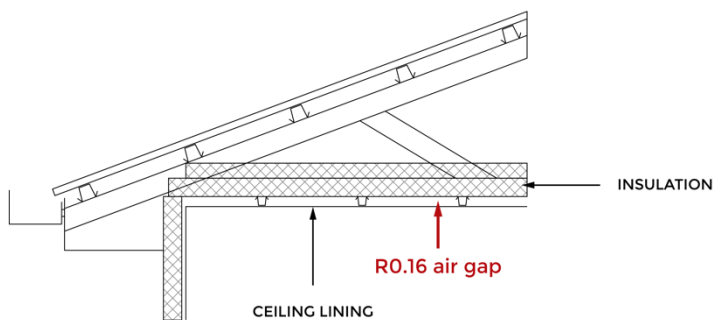

Figure 11-11

For floors:

If available in the software apply the R0.16/air gap option to any thermally bridged suspended floor above and exposed to an enclosed subfloor space, e.g. no bottom lining. This is to take account of the benefit provided by the sub-floor airspace in reducing thermal bridging of the frame. See Figure 11-12 below.

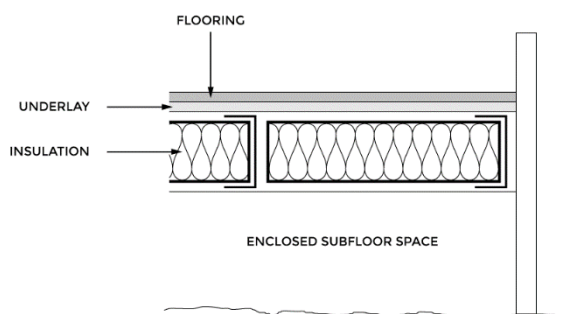

Figure 11-12

11.5 Additional constructions modelling guidance

Continuous insulation/continuous thermal break directly adjacent to and touching the insulated steel frame

If continuous insulation is applied directly adjacent to and touching the steel frame, this should currently be modelled by:

1. modelling the insulation according to the software's instructions, e.g. as a separate construction layer, and
2. ticking the thermal break box R0.2.

Roof blankets

Roof blankets do not currently need to be modelled for thermal bridging.